PLATINUM REFRIGERATION RANGE

USER GUIDE AND OPERATING INSTRUCTIONS

LRE 120 | 440

PRE 120 | 440

Contents

Page

Introduction	4
Further information about the appliance	4
Symbols	4
Abbreviations	4
Safety	5
Intended use	5
Personal safety	5
Handling & Transportation	6
Moving the appliance	6
Packaging	6
Unpacking	6
Inactivity for extended period	7
Disposal	7
Installation	7
Preparing the appliance	7
Location	7
Electrical connection	10
Remote alarm contact (installation)	11
Getting started	11
Product description	12
Cabinet description	13
Probes and portholes	14
How to mount shelves	16
How to mount the handle	17
Remote alarm contact (description)	18
Control panel	19
Buttons on the keyboard	19
Button combinations	20
LED icons on the display	21
How to change the parameters	22
Light	22
Error codes	23
Default settings	23
Cooling system	24
Rating plate	24

Contents

Page

Maintenance

25

General maintenance

25

Cleaning

25

Defrosting

26

Service

27

Spare parts

27

After-sales

27

Warranty

27

Trouble shooting

28

Introduction

Please take a few minutes to read and become familiar with the advantages of your appliance.
Read these operating and installation instructions before switching on the appliance.

Symbols

- !** **WARNING**
Performing this action can cause personal injury.
- !** **CAUTION** - Risk of personal or material injury. Consult the instructions before attempting to use this equipment.
- !** **Prohibition**
Action is strictly prohibited.
- !** **Follow procedures**
Keep the instructions handy for convenient reference.
- !** **OFF**
Disconnect power supply before operation.
- !** **Grounding**
Be aware that the unit is grounded.
- !** **Fragile - Handle with care**
Indicates a device that can be damaged or broken if not handled with care.

Abbreviations

A Ampere	MM Milimeter
V Volt	Min Minutes
W Watt	H Hour
C Degree Celcius	NIA Not applicable
Kg Kilogram	

Safety

Rollex Medical is obligated as a supplier to ensure the users safety when operating one of our units. To prevent personal and material injury or damage, please follow the instructions.

Intended use

The PLATINUM units are designed for storage of biomedical products at a constant temperature in clinical, pharmaceutical, research and laboratory fields.

The PLATINUM units are designed to operate within a temperature range for refrigerators from +2°C to +8°C and freezers from -15°C to -25°C at maximum +32°C ambient temperature. For safe and optimal performance of the unit, it should only be placed indoor, in a well ventilated room and in elevations less than 2000 m. Usage of the unit should only apply to instructed personal.

Personal safety

When operating a PLATINUM unit, your body is exposed to a variation of possible dangerous events.

- Read and understand this manual. If in doubt, contact Rollex Medical
- Assure good cleaning practices at all times by keeping the equipment and the adjacent areas clean, dry and uncluttered.
- Should any malfunctions occur or be suspected, immediately call a qualified service engineer to investigate.

Do not insert metal objects such as a pin or a wire into any vent, gap or any outlet on the unit. This may cause electric shock or injury by accidental contact with moving parts.

When removing the plug from the power supply outlet, grip the power supply plug, not the cord. Pulling the power cord may result in electric shock or fire by short circuit.

Handling & Transportation

Moving the appliance

Lifting, moving and transportation of the appliance without suitable equipment may cause personal injury or material damage. Always use suitable lifting equipment to load, unload and move the appliance.



Disconnect the power cord before moving the unit. Make sure not to damage the power cord. A damaged power cord may cause electric shock or fire.



Be careful not to tip the unit over during transport to prevent damage or injury.

Packaging

- Do not expose the package to rain.
- Always keep the package upright. **DO NOT BRING THE PACKAGE TO HORIZONTAL POSITION.**
- Do not expose the package to bumps and shocks.
- Package contents are fragile.

Unpacking

1. Inspect the packaging carefully for any damage that may have occurred during shipping. If damage is observed, report to the shipping company and your local distributor.
2. Remove all packaging material, plastic and straps. All packing materials are entirely recyclable. For more information on where to dispose of waste, contact your local authority or recycling station.

Inactivity for extended period

If the appliance must be switched off for a longer period and stored away, please take following precautions.

- Clean the appliance both inside and outside.
- Ventilate the appliance and make sure it is completely dry.
- Disconnect the power cord.
- Leave the door slightly open in order to prevent rot and mold.



Disconnect the power plug when the unit is not in use for a longer period. Keeping the connection may cause electric shock, current leakage or fire due to the deterioration of insulation.



If the unit is to be stored unused in an unsupervised area for an extended period, ***ensure that children do not have access and that doors cannot be closed completely.***

Disposal

In the event of disposal of the appliance, observe relevant legal regulations to prevent harmful environmental effects.

This appliance is marked in compliance with the 2002/96/CE European Directive, WASTE ELECTRICAL AND ELECTRONIC EQUIPMENT (WEEE).

Installation

Preparing the appliance

- **Unpack the unit:** Remove all packaging materials, plastic bags and straps.
- **Storing the key:** The key for the door lock is placed in a plastic bag inside the unit. Keep the key in a safe place.
- **Read the Quick start guide:** The quick start guide is provided with the unit.
- **Ventilate the unit:** Open the door for at least 20min, in order to ventilate the unit before first use. The unit may contain odors from manufacturing.
- **Clean the unit:** Clean the unit on the inside and outside with a soft cloth/ sponge using a solution of water and light detergent. After cleaning all surfaces of the unit, wipe the inside with a dry rag.

Refrigerant

Please see the serial plate affixed to the appliance, to obtain information about the refrigerant.

The appliance contains a flammable refrigerant.

Location

Place the unit on a location that satisfies the following conditions in order to achieve optimal operating results.

- **Firm and levelled floor:** Installing the unit on a firm and flat floor reduces the risk of excessive noise and vibration.
- **Away from any heat sources:** Avoid placing the unit near any heat dissipating devices such as a gas burner/stove, radiator, oven and other source of heat. The unit will lose its efficiency once the insulation is exposed to heat.
- **Place the appliance away from direct sunlight:** Placing the unit in direct sunlight may cause reduced performance and shorten the life expectancy.

- **Dry area:** Avoid placing the unit near damp areas such as a water faucet and sinks.
- **Clean area:** Placing the unit in a clean environment will reduce risk of function failure. Avoid installing a unit in or near chemicals and materials that might have outgassing property to avoid corrosion.
- **Well ventilated:** There must be sufficient space around the unit for air ventilation. Lack of such space will reduce the unit's cooling capability. Place the unit with at least 10cm free space to each side, of the unit (left, right, back and top).
- Do not place any objects on top of the unit.



An electrical power plug with a ground prong must be used to power the unit. This is to prevent electrical shock.



Do not use the unit outdoors. Current leakage or electric shock may result if the unit is exposed to rain.



Never install the unit in a flammable or volatile location. This may cause explosion or fire.



Install the unit on a sturdy floor and take an adequate precaution to prevent the unit from tipping.

Electrical connection

In order to ensure an economical and reliable installation that complies with the limits of temperature and voltage drop, it is necessary to determine maximum load of appliances connected to the installation. In determining the maximum load for an installation or for a part of it, it is required to take into account contemporaneous factors. For supply systems, the following must be determined:

- Power system (AC/DC) - Data regarding voltage and absorbed power/ current is given on the rating plate.
- Ground protection: Grounding the appliance will prevent the user from getting exposed to electrical shock in case of electrical insulation damage.
- The installation must always be secured with a minimum 10 A fuse.
- If you have more than one unit, each unit must be connected to an individual fuse group.

If the connection is a 3-pole connection, use a three-pin plug and connect the conductor with yellow / green insulation to ground. In order to maintain a stable operation of the unit, voltage variation cannot differ more than ± 10 percent of the nominal voltage supply. Always follow local regulations when preparing an installation. Contact your local authorities if in any doubt.



Always make sure the unit is grounded to protect the user from electrical shock.



Do not use the power supply cord if it is damaged. Such supply cord may cause fire or electric shock.



Never use a telephone line or lightning rod as ground protection. During lightning, there is a strong current present, which is extremely dangerous.



Do not use water pipes as ground protection. Modern water pipe systems are non-conductors such as PVC.



Replacing the power cord may only be done by authorized personal.



Never use gas lines as the ground protection for the unit. This can cause an explosion.



Disconnect the power cord if there is something wrong with the unit. Continued abnormal operation may cause electric shock or fire.

Remote alarm contact (installation)

The terminals for the remote alarm contact are located on the back of the unit (see “Cabinet description”). The contact design is for 30 VDC and 2A load. The remote alarm contacts work in synchronization with the buzzer alarm on the appliance. In order to terminate the remote alarm push the buzzer alarm button. However, in case of a power outage, the remote alarm contacts cannot be controlled by the buzzer alarm. Remote alarm setting between: Normally open and normally closed.

Getting started

During the initial startup and continuous usage of the appliance, the following procedures shall be followed.

1. Plug the power socket in a dedicated outlet. For correct voltage requirement, follow the information on the rating plate. When started, let the appliance cool for minimum 2 hours before placing any products in it. During transport it is probable that the compressor oil has entered the cooling system blocking the capillary. As a consequence, the appliance will function for a certain period of time, though without cooling, until the oil has returned to the compressor.
2. When the appliance initially starts up, the buzzer alarm may sound. This is normal. You can push the buzzer alarm button to cancel the sound.
3. This appliance has been factory set to operate at +5°C (refrigerator) or - 20°C (freezer).
4. The light can be turned on and off (see the menu “Light”).

5. Once a thorough inspection of the appliance is completed, products can be loaded into the appliance. Be aware not to load too many warm products into the appliance at one time as this can affect the cooling performance of the appliance.

Product description

The PLATINUM range offers high performance and stability. Low noise level, low energy consumption, low heat dissipation and excellent temperature stability.

Ergonomically work position and less generation of heat in your working area.

Cabinet description



1. Top panel	Fitted with controller.	12. Compressor compartment	Compressor compartment on the back of the unit.
2. Controller	See "Controller Carel"	13. Shelves	Adjustable shelves.
3. LED light	Secure work light.	14. Water drain	Drain for the condensation water.
4. Rating plate	See "Rating plate" for more information.	15. Porthole	See "Probes and portholes".
5. Door with handle	The handle on the door.	16. Evaporator	Provides a constant temperature.
6. Magnetic door gasket	Ensure proper door closing.	17. Condenser	Part of the cooling system.
7. Probe	See "Probes and portholes".	18. Antifreeze	
8. Shelf holder	Holder for the shelves.	19. Fan	
9. Shelf guide	Ajustable shelf system.	20. Remote alarm contact	For connecting additional alarm equipment/remote alarm.
10. Basket	Removable basket.	21. Door switch	Monitors the door openings and controls the lights
11. Rollers	Rollers for easy moving of the unit.	22. Door lock	For easy opening, closing and locking door.

Probes and portholes

As standard, the unit is equipped with a temperature probe inside the unit. The probe monitors the temperature in the chamber and controls the operation of the compressor. The main probe also controls temperature alarms. It is possible to connect external probes inside the unit in order to monitor the temperature different places in the unit. To install external probes you can use the portholes on the back of the unit.

How to install an external probe



Never install probes through the door as this will deteriorate the functionality of the door gasket and the temperature inside the unit.

Shelves

As standard, the unit comes with shelves that are easy to set up. Always make sure the shelf holders are levelled to avoid leaning shelves.

How mount the shelves:

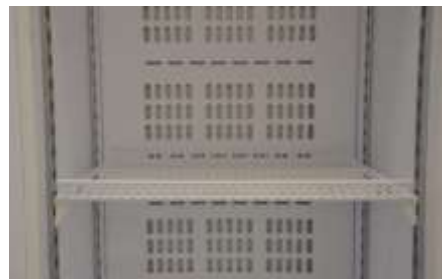
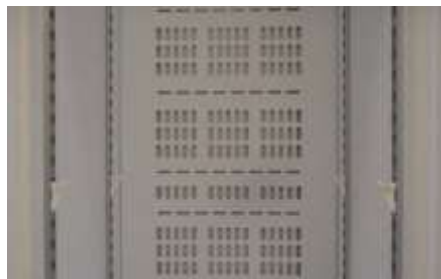

Door with handle

As standard equipment, the unit comes with an easy attachable door handle.

How to mount the door handle:

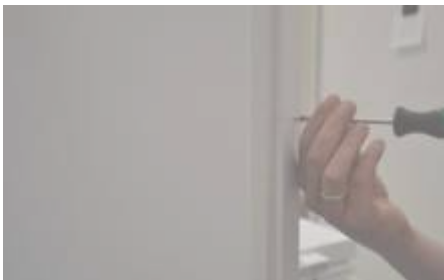

Unscrew the two screws.



Unpack the handle.



Mount the handle onto the door.



Repeat last step.

Remote alarm contact (description)

The appliance is equipped with a voltage free remote alarm contact, which can be connected with a CTS system or other external monitoring system. The remote alarm contact works in synchronization with the buzzer alarm on the appliance. In order to terminate the remote alarm, push the buzzer alarm button . However, in case of a power outage, the remote alarm contact cannot be controlled by the buzzer alarm.

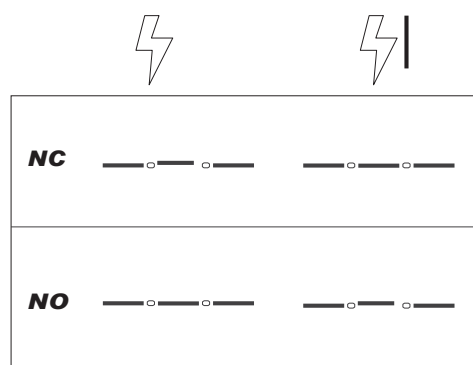
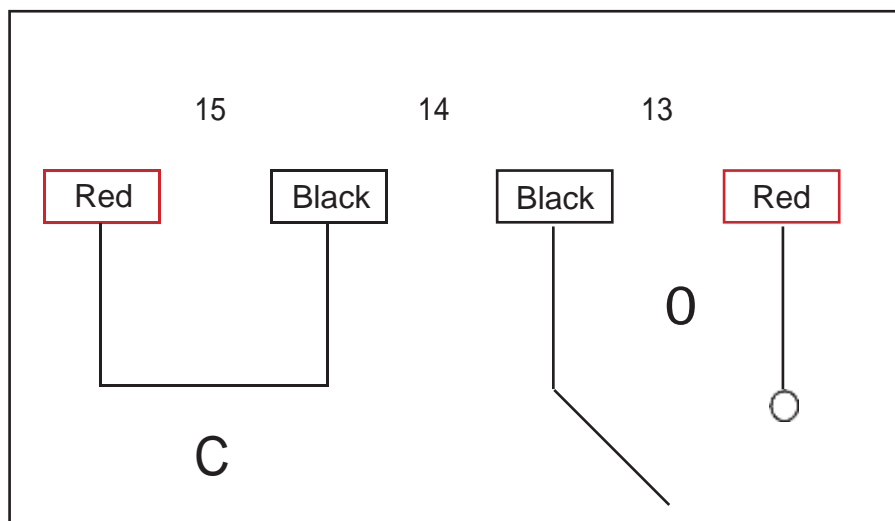

Antifreeze function

The appliance is equipped with a voltage free remote alarm contact, which All PLATINUM refrigerators are equipped with antifreeze function. The antifreezefunction prevents negative chamber temperatures, ensuring that the storedmaterial is always kept at positive temperatures.

The antifreeze thermostat adjustment screw is located on the rear side of the appliance (see section “Cabinet description”).

IMPORTANT! The antifreeze thermostat is preset during production. Changing the settings of the antifreeze thermostat must be avoided.



Control panel

1

2



Buttons on the keypad



1. PRG/MUTE

To silence audible alarm (buzzer) and disables the alarm relay.

Press for 3 s to access parameters.



2. ON_OFF/UP

Press 1 s to enable the regulation of the unit. Press 3 s to disable the regulation of the appliance.

During the parameters modification, increase the value displayed and move towards the next parameter.



3. SET/DEF

Press 1 s to enable/display and/or set the set point.

Press 5 s to enable manual defrost (only on selected models).



4. AUX/DOWN

Enables/disables the auxiliary output. To enable/disable, press for 1 s.

During the parameters modification decrease the value displayed or move towards the previous parameter.

Press to switch ON/OFF light on PRE 120 and PRE 440

Button combinations



+



If pressed together for more than 3 s; Reset any alarm with manual reset.



+



If pressed together for more than 3 s; Enable/disable the continuous cycle operation.



+



If pressed together for more than 3 s; Display the temperature read by the defrost probe no 1.



+



If pressed together for more than 1 s; Display a submenu with the HACCP alarm parameters (HA, HAn, HF, HFn).

LED icons on the display

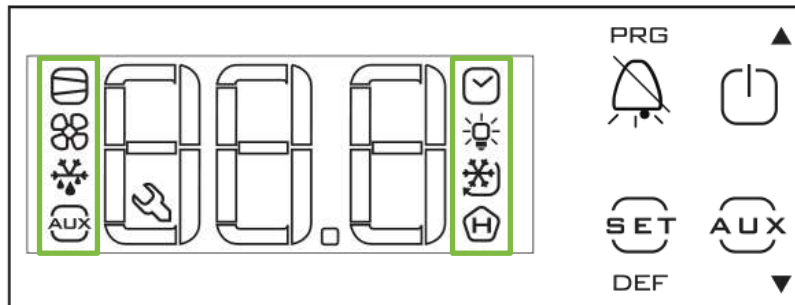



Icon	Function	LED light display		
		ON	OFF	Blink
	COMPRESSOR	Compressor ON	Compressor OFF	Compressor enabled
	FAN	Fan ON	Fan OFF	Fan enabled
	DEFROST	Defrost in progress	Defrost not required	Defrost enabled
	AUX	Auxiliary output AUX active	Auxiliary output AUX not active	Anti-sweat heater function active
	ALARM	Delayed external alarm	No alarm present	Alarms and malfunction active
	CLOCK	At least one timed defrost has been set	No timed defrost is set	Clock alarm
	LIGHT	Auxiliary output LIGHT active	Auxiliary output LIGHT not active	Anti-sweat heater function active
	SERVICE		No malfunctions	Malfunction (see error codes.)
	HACCP	Function not enabled	Function enabled (HA and/or HF)	HACCP alarm enabled
	CONTINUOUS CYCLE	Function enabled	Function not enabled	Function enabled







How to change the parameters

The parameters should only be programmed or modified by personnel who know the equipment, its operation and the possibilities of the equipment where applicable.





Access to the parameters

- 1: Press "" for 5s, the display will show "PS" (Password);
- 2: It will appear 0
- 3: Confirm the password (PS), pressing "";
- 4: Press " " and it will appear the first parameter

Modify and memorize the parameters

- 1: Press " " or " " and scroll inside the parameters.
- 2: Press "Set" to display the values of the parameter displayed.
- 3: Increase or decrease the value using " " or " ".
- 4: Press " " to return to parameters. To exit the parameter without saving the changed values (exit by timeout) do not press any button for at least 60 s. To exit parameters with record of the changes, press " " for 5 s.

Setting the set point (desired temperature)

- 1: Press " " for 1s, the set value will start flashing after a few moments.
- 2: Increase or decrease the value using " " or " "
- 3: Press " " to confirm the new value.

Light

All PLATINUM refrigerators are equipped with an interior

light. **Models with glass door:**

Press the " " button to activate/deactivate the light. By activating the light, it will be constantly turned on.

Models with solid door:

The light activates during door openings and turns off when closing the door.

Error codes

Message	Description
rE/E0	Environment probe error
E1	Defrost probe error
LO	Low temperature alarm
HI	High temperature alarm
dEF	Defrost running
OFF	Standby
dor	Open door
EE	EPROM error, unit parameters
EF	EPROM error, operating parameters
dFb	Request to start defrost
dFE	Request to end defrost

Default setting values

Parameters	Code	Refrigerators	Freezers
Setpoint	St	5	-20
Hysteresis	rd	2	3
Display defrost probe	d/1	---	---

Cooling system

The PLATINUM range is fitted with a ventilated cooling system. The evaporator is an integrated part in the unit and divides the thermal radiation into levels inside the cabinet ensuring uniformity.

Rating plate

The rating plate is placed on the front right side inside the unit.



- | | | |
|------------------|---------------------|---------------------------|
| 1. Company logo | 5. Volume gross/net | 9. Frequency |
| 2. CE marking | 6. Foam agent | 10. LED light info |
| 3. Model | 7. Climatic class | 11. Refrigerant charge |
| 4. Serial number | 8. Power supply | 12. Manufacturer contacts |

Maintenance

Frequent and correctly executed maintenance is essential to ensure high performance and functionality of the unit. Rollex Medical recommends a thorough examination once a year and cleaning at least once a month.



Never disassemble, repair, or modify the unit yourself. Any such work carried out by an unauthorized person may result in fire, or electric shock or injury due to a malfunction.

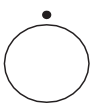

Before performing maintenance or cleaning the unit, **disconnect the electrical power supply.**



Ensure that you do not inhale or consume medication or aerosols from the unit at the time of maintenance. These may be harmful to your health.



Never splash water directly onto the unit as this may cause electric shock or short circuit.

General maintenance

Perform following at least twice a year:

- Lubricate hinges and gaskets. Wipe off all excess lubricant.
- Make sure the appliance is levelled. If necessary, adjust castors/feet.
- Inspect all seals and gaskets. Make sure they are still soft and flexible.



WARNING!

Before any inspection or maintenance work is performed, the power plug of the unit should be disconnected from the power supply socket. This is to prevent any potential electrical shock or injury. During the maintenance work, do not breathe the dust and aerosols near the unit; they might be harmful to your health.

Cleaning

Perform following instructions at least once a month:

- Always keep the appliance free of ice. Use a soft cloth or brush to remove loose ice. Never use sharp tools and be cautious not to damage rubber seals and gaskets. Keeping the appliance free of ice will extend it's lifespan.

- Clean the outside and inside of the appliance using a dry, soft cloth or a soft cloth with a solution of water and mild detergent. If a thorough cleaning or disinfection is required, we recommend using ethanol.
- Clean all seals and gaskets using a damp cloth and if necessary a mild detergent. Remove dirt and wipe with a dry cloth afterwards.
Do not pour water directly into the unit. By doing so, the water can damage the insulation materials and electrical components.
- Dust off the inside of the compressor department using only a dry brush. Parts in the refrigeration system of this unit are completely sealed. They do not require any lubrication.



ATTENTION!

Do not use abrasive nor chlorine-containing products to clean the appliance.

Defrosting

(only applicable for freezer models)

The controller automatically controls the defrosting of the evaporator. Defrosting is indicated on the display by the relevant LED icon. During defrosting of the evaporator, it is recommended not to load or unload the refrigerated compartment.

We recommend to defrost the complete appliance at least once a year.

1. If the appliance is loaded with products, move these to another appliance to maintain the temperature of the products.
2. Turn off the appliance on the display by pressing the ON/OFF button.
3. Unplug the main power cable from the power socket.
4. Open the door of the appliance.
5. Place cloths or towels in the bottom of the appliance to collect and limit defrost water.
6. Leave the appliance open for a minimum of 24 hours allowing the ice to melt.
7. When the defrosting is completed, thoroughly clean the appliance inside. Wipe off all remaining water and leave the door open until the cabinet is completely dry.

8. Connect the main power cable to the power socket and switch on the appliance on the display by pressing the ON/OFF button .
9. Reload the appliance after reaching the set temperature.

Spare parts

For requirements of spare parts, contact Rollex Medical.
Please inform the unit's serial number and model.

Troubleshooting

Malfunction often arise due to wrong use of the appliance and can often be solved on the spot. In order to resolve some of the most common malfunctions, please see the following troubleshooting scheme:

Problem	Cause	Action
Unit's refrigeration is not effective, temperature tends to operate out of range.	Dirty condenser.	Clean the condenser.
	Insufficient door sealing.	Check the gaskets.
	Hot gas valve partially open.	Contact Rollex Medical
	Overload or load of warm products may cause the temperature to rise.	Discharge warm or excess products.
	Products are packed too close in the unit, preventing air to flow.	Relocate the products. Make sure there is an air gap between products.
	Make sure the unit is not in direct sunlight or subject to any heat radiation.	Move the unit away from the sunlight or heat source.
	Frequent door openings may cause the temperature to rise.	Check if there has been frequent door openings. Leave the door closed until the temperature in the unit is stable.
	The ambient temperature is too high. The unit is most effective in an environment below the max ambient temperature listed on the serial plate of the appliance.	Control the room temperature in the room where the unit is located.
The unit is too noisy.	The unit is not levelled.	Adjust the castors/feet.
	The unit is touching a wall or object.	Move the unit away from the wall or objects.
	Warm products are loaded into the unit. The alarm signal cancels when the temperature recovers to normal level.	Allow time for the temperature to recover. The alarm will stop when the temperature has recovered.
Alarm light flashes, alarm buzzer sounds.	Door is not shut properly. The Door alarm will sound if the door is even slightly opened.	Shut the door.
	Unstable power supply might cause the alarm to switch on.	Allow time for recovery.